

MODELS: PAVER-CP-MT
PAVER-CP-AWS
PAVER-CP-MT-MSI

Paver Control Panel Kits

Stainless Steel Control Panel for use with Fire Pits built with Patio Paver Blocks

Installation and Operating Instructions

**IF YOU CANNOT READ OR UNDERSTAND THESE INSTALLATION INSTRUCTIONS
DO NOT ATTEMPT TO INSTALL OR OPERATE THIS APPLIANCE**

CALIFORNIA PROPOSITION 65

WARNING

This product is designed to operate with one of the following fuel sources: Liquid Propane or Natural Gas. The fuel used to operate this product, and the products of combustion of such fuel, can expose you to chemicals including Benzene which is known to the State of California to cause cancer, birth defects and other reproductive harm and Carbon Monoxide which is known to the State of California to cause birth defects or other reproductive harm.

(For more information go to: www.p65Warnings.ca.gov.)



Warning: For Outdoor Use Only



PLEASE RETAIN THIS MANUAL FOR FUTURE REFERENCE

Table of Contents

Description	Page 2
General Instructions	Page 2-3
AWS Illustration	Page 4
PAVER-CP-MT	Page 3-5
PAVER-CP-MSI	Page 5-8
Warranty	Page 8
Replacement Parts	Page 9

Note: Stainless steel parts have plastic film to protect the surface on one side. **PEEL** the plastic coating off each part before installing.

DESCRIPTION: The Paver Kit face plate bracket (control panel) is designed to install in conjunction with a typical paver block fire pit kit (purchased separately). It installs underneath the fire pit pan/disc in place of one patio block. The control panel itself provides a convenient location to house the gas valve and Piezo ignition (if applicable) then is easily removed for servicing.

PRECAUTION: If you are installing the MSI (Manual Spark Ignition) ensure the PAVER-CP-MT-MSI control panel is within 40-inches of the 2-probe Piezo ignitor. This will allow enough "play" in the wires to make your connections. See Fig. 19 on page 7.

This installation instruction covers two (2) separate kits: 1) PAVER-CP-MT and 2) PAVER-CP-MT-MSI.

TOOLS NEEDED: (1) Drill/driver, Gas Rated Teflon Tape or Compound, 5/16" Hex head driver, (1) 3/16" Concrete Drill Bit, (2) Adjustable Wrenches, Assorted Open-end Wrenches

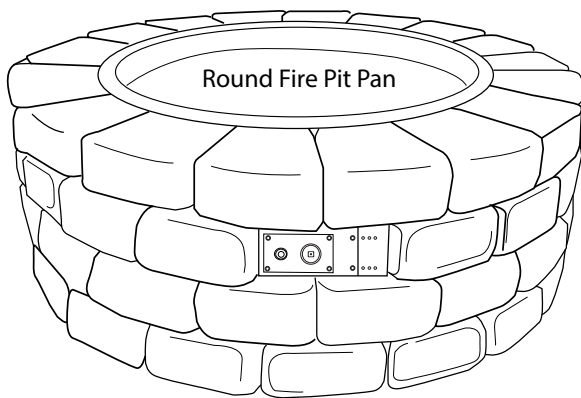

Fig. 1 Paver kit with fire pit pan.

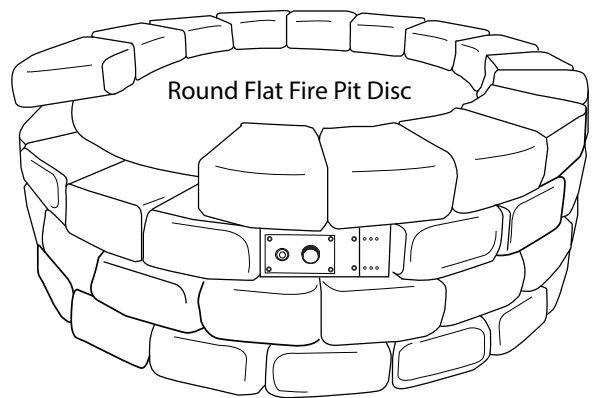

Fig. 2. Paver kit with fire pit flat disc with flex frame.

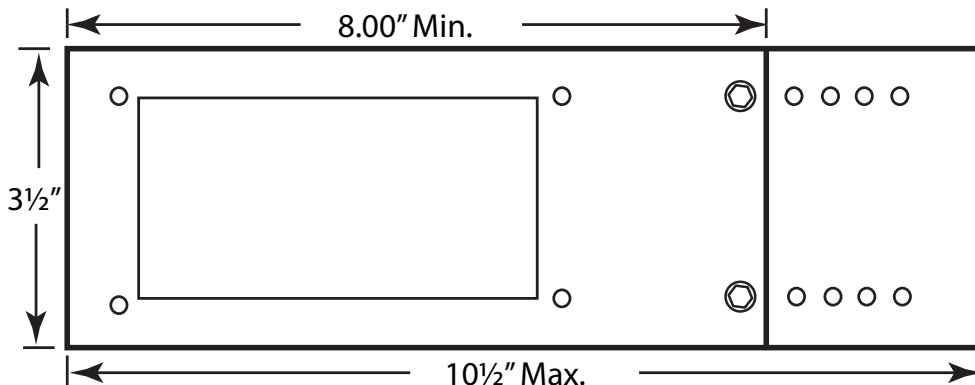

Fig 3. Paver Kit Control Panel Dimensions

DIMENSIONS: The Paver Kit bracket and extension will fit an opening with a maximum of 10½" wide x 3½" tall. Without the Bracket Extension plate the maximum width is 8" wide. The holes in the Extension Bracket are spaced every ½".

GENERAL INSTRUCTIONS

NOTE: This manual covers two specific models. This section will provide a general installation of the Paver Control Panel. See Table of Contents for specific instruction for your application. Follow the directions from your paver block fire pit kit to build the actual fire pit. Depending on your fire pit pan (flat disc or pan) ensure the Paver Control Panel is installed underneath the pan or disc.

Be sure the paver patio block kit fits the opening of the fire pit pan or disc before beginning your installation.

STEP 1: Determine the best location to install the paver kit control panel per your installation.

STEP 2: Remove one block from your fire pit enclosure then measure the width between the opening. Depending on the block width the control panel can be adjusted to fit various openings. **NOTE:** When measuring it is recommended but not required to recess the control panel to protect the valve components from weather.

STEP 3: After you have determined the location and measured the width to install the Paver Control Panel mark the inside of the control panel as shown in Fig. 4.

STEP 4: Drill the two holes with a 3/16" concrete drill bit and secure the paver kit control panel with concrete screws. Fig. 5 shows front view.

Use the lintel to support the paver above control panel. The lintel simply lays on top of the paver as shown in Fig. 4.

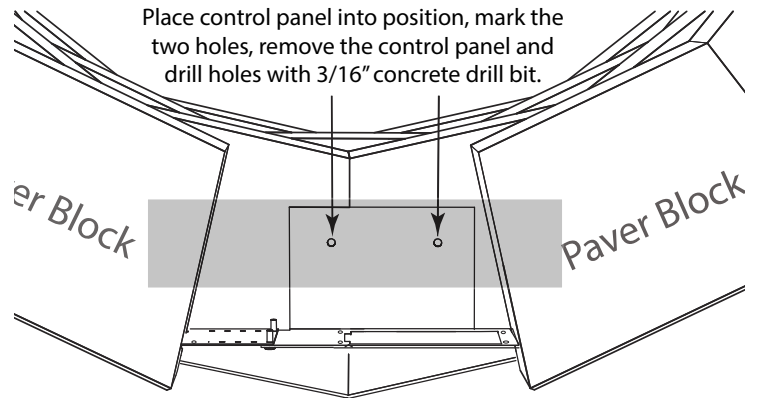

Fig. 4 Top view of control panel securing into the paver block.

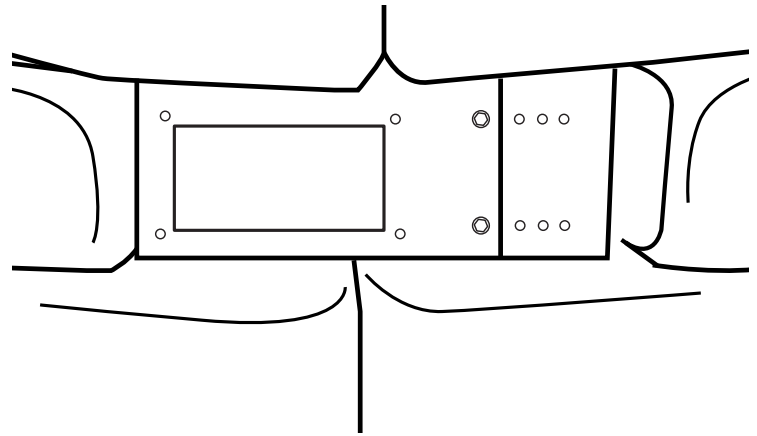

Fig. 5 Front view of control panel installed, ready for valve bracket.

PAVER-CP-MT INSTRUCTIONS

With the paver kit face plate bracket (control panel) installed you are now ready to install the manual gas valve.

STEP 1: Prepare the two 1/2" flare x 1/2" MIP 90° brass elbows by installing gas rated Teflon tape or compound to the male threads and install them into the manual key valve that came with your fire pit. Ensure the fittings are tight to prevent any gas leaks. See Fig. 6 for proper orientation.

NOTE: The manual key valve has no particular inlet or outlet designation therefore the inlet gas can be connected to any of the flared ends.

CAUTION: Do not use any Teflon tape or compound on the flared ends of the fittings.

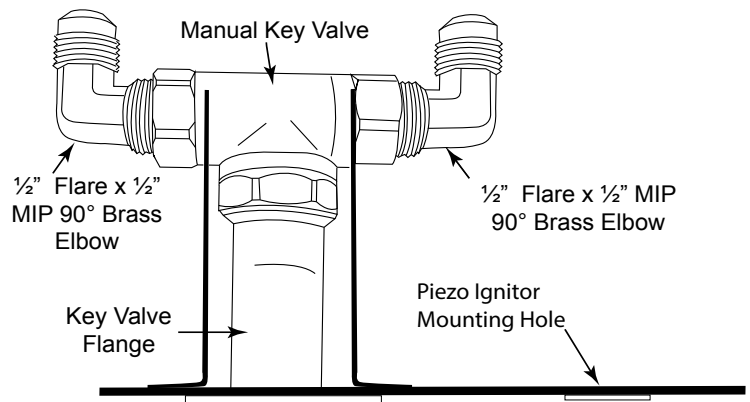

Fig. 6 Manual key valve elbow orientation. **Note:** The paver kit face plate bracket (control panel) can be oriented with Piezo on either the right or left hand side.

STEP 2: Once the 90° elbows are installed into the manual key valve then install the MT key valve bracket into Paver Kit control panel as shown in Fig. 7.

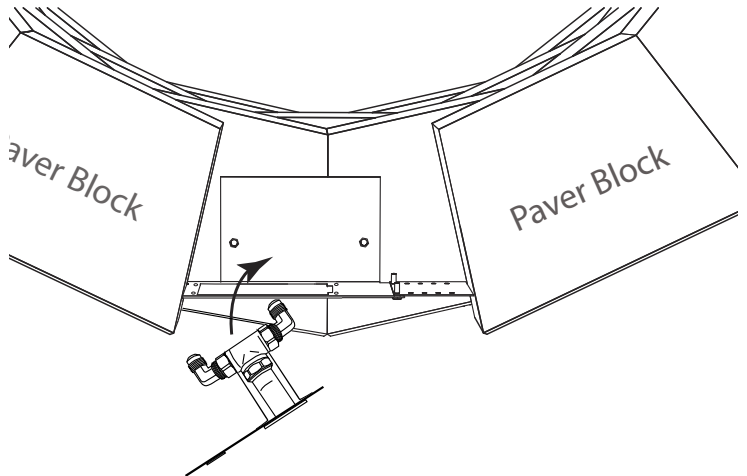

Fig. 7 Installing MT valve into control panel.

STEP 3: Secure the key valve bracket into place using the four black thread cutting screws (See Fig. 8).

STEP 4: Install the flex connector from the burner to either side of the gas valve and connect gas supply to the other side of the gas valve. Conduct a trial burn test by temporarily connecting the fire pit pan and burner and check for any gas leaks before completing the installation. See fire pit manual for proper connections.

See page 5 for lighting instructions.

STEP 5: After burn test is complete, finish the patio paver blocks installation.

Note: If installing an AWS valve use the switch plate supplied with the AWS system. Install the switch plate into the paver bracket as shown in Fig. 9. Use AWS manual for lighting information.

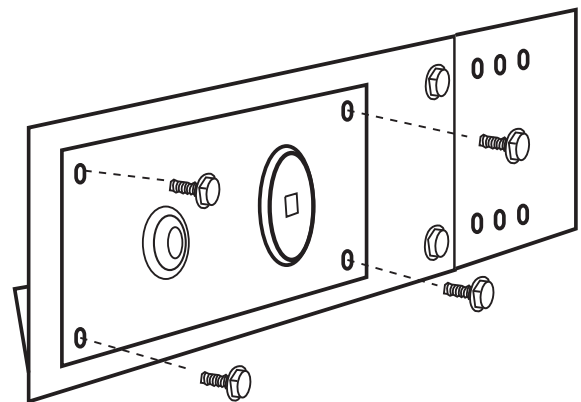

Fig. 8 Close up view securing MT face plate into the paver bracket..

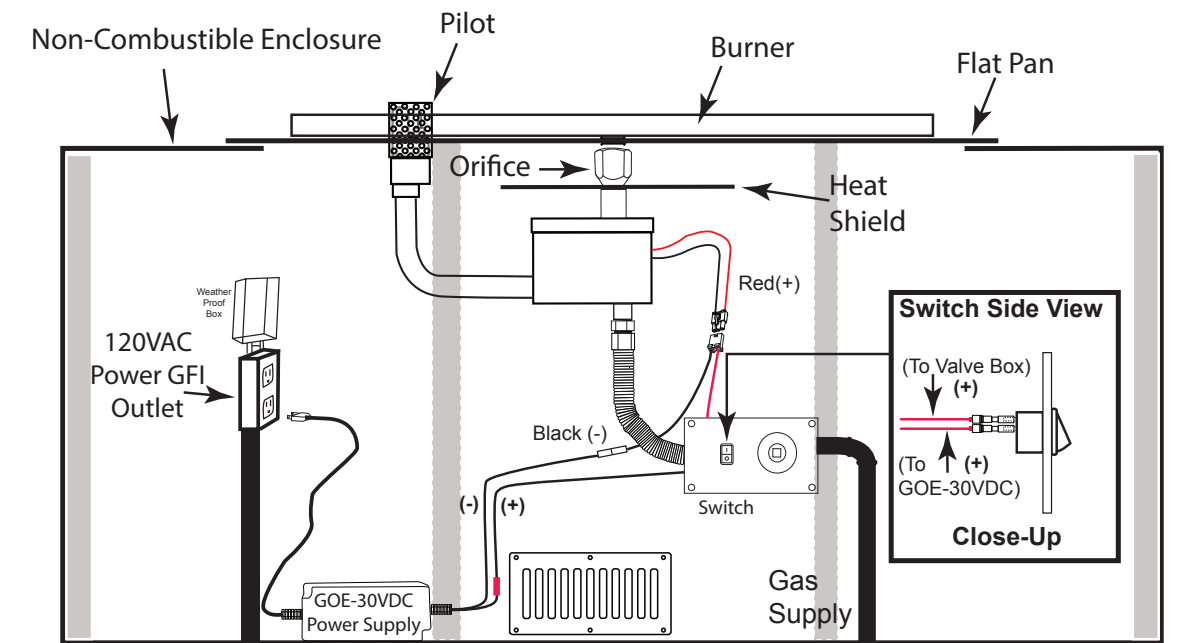

Fig. 9 Shows the AWS system installed using the switch plate.

MT LIGHTING INSTRUCTIONS

READ ALL WARNING AND SAFETY INFORMATION ABOVE BEFORE ATTEMPTING TO LIGHT FIRE PIT

CAUTION: ENSURE YOU HAVE LEAK TESTED THE FIRE PIT BEFORE OPERATING

TURNING ON FIRE PIT

1. Insert key into shut-off valve and secure into square end (see Figs 9-11).
2. Light a long match or butane lighter and hold it near the burner.
3. Turn the key slowly counter-clockwise in gas valve (until it stops) to allow gas to flow and simultaneously apply the long burning match or Butane lighter as close to the end burner as possible to light the fire pit.
4. Gas should ignite within 10 seconds or less. If fire pit does not light within 10 seconds turn key clockwise to turn **OFF** the gas supply. Ensure there is not too much media on top of the burner that might inhibit gas flow and try again in 5-minutes.

TURNING OFF FIRE PIT

1. Insert key into shut-off valve and secure into square end.
2. Turn key clockwise until it stops.
3. After cooling off install cover.

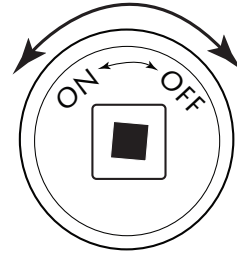

Fig. 10. Key Valve Face

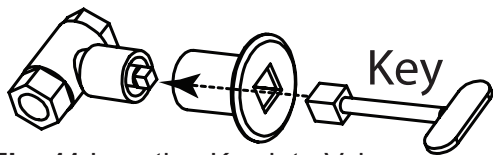

Fig. 11 Inserting Key into Valve

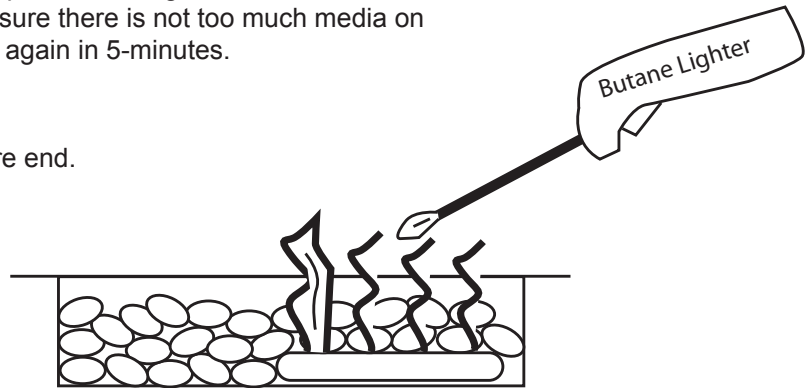

Fig. 12 Lighting fire pit with lighter

PAVER-CP-MT-MSI INSTRUCTIONS

Tools Needed: Power Screwdriver with a, $\frac{5}{16}$ " hex head tip or a $\frac{5}{16}$ " nut driver.

CAUTION: Turn OFF main gas supply before installing.

Step 1: Remove the burner pan from the enclosure (if applicable) or remove the fire pit from the carton.

Step 2: Invert the burner pan up side down and remove the four hex head screws from the cover plate. See Fig. 13. Discard cover plate after removal.

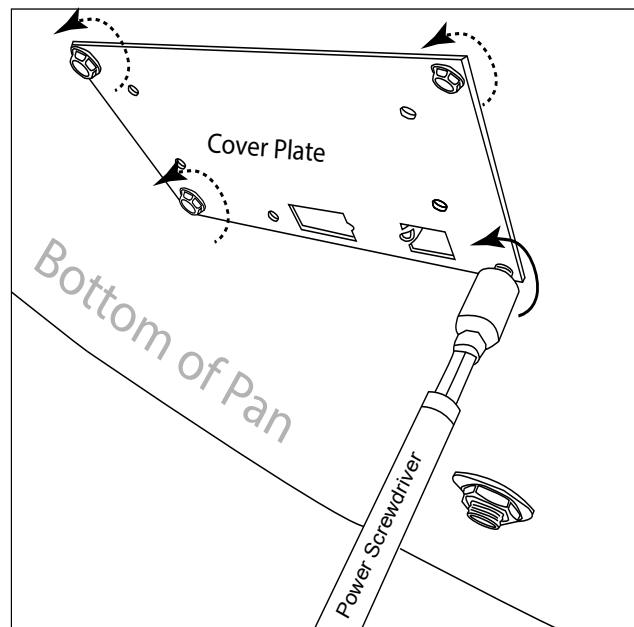

Fig. 13 Removing 4 cover plate screws.

Step 3: Install the MSI ignition assembly from the bottom of the pan as shown in Fig. 143. **Note:** The hood will slide over top of the burner leg as shown in Fig. 15.

Step 4: Secure the MSI ignition assembly to the pan using the four previously removed screws. **Note:** The metal tab aligns the burner leg underneath the spur hood as shown in Fig. 14.

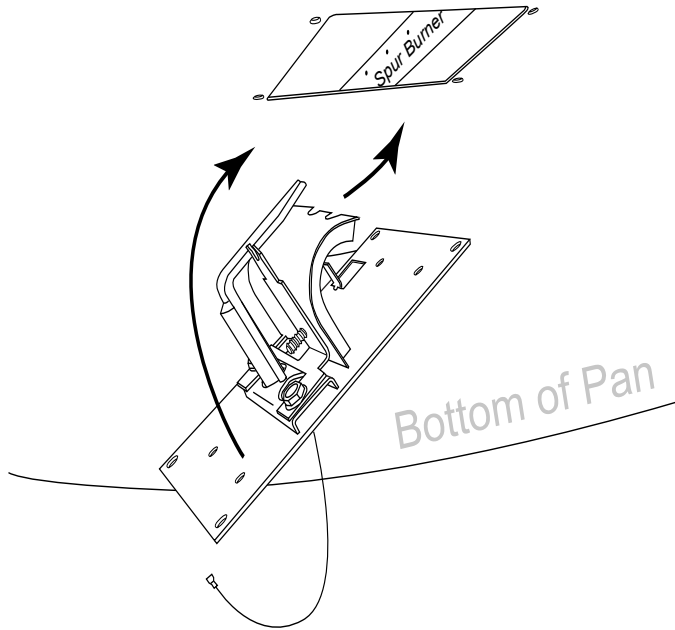

Fig. 14 Installing MSI assembly into bottom of pan.

Step 5: Using a power screwdriver install the ignition hood over top of the MSI assembly plate. See Fig. 16. Align the five holes from the ignition hood to the five hole of the assembly plate, then secure in place with provided screws.

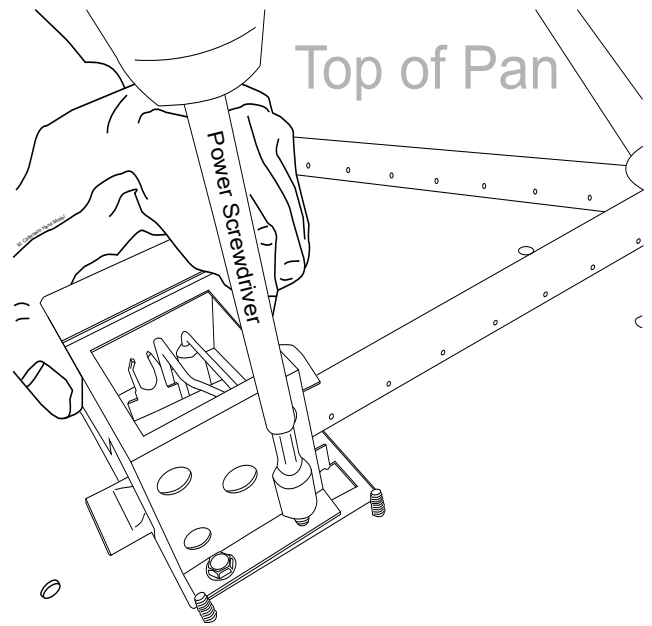

Fig. 16 Installing ignition hood.

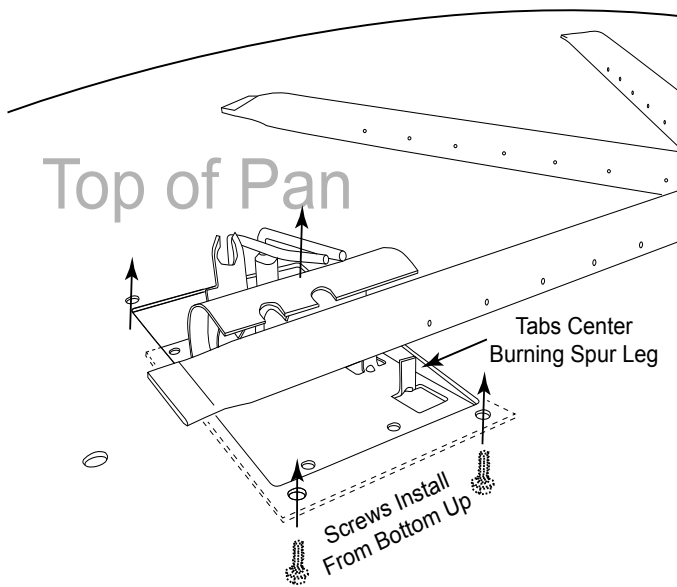

Fig. 15 Installing screws from bottom of pan.

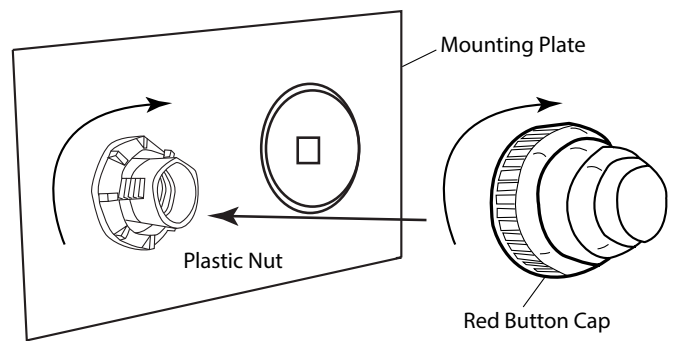

Fig. 17 Installing battery into Piezo module.

Step 5: Install the ignition hood over top of the ignition probe assembly into the existing pre-punched holes of the burner pan by using the five #10 - 24 x 1/2" provided screws. (See Fig. 18).

Step 6: Ensure the Paver kit control panel is within 40-inches of the 2-probe Piezo ignitor. This will allow enough "play" in the wires to make your connections. If not you may have to rotate the pan or disc to make proper connections.

Step 7: Connect the 3/16" end of the PIEZO23WH extension wire and 3/16" end of the PIEZO48WH wire into the back side of the spark ignitor module. See Fig. 19 detail.

Step 8: Attach the 1/4" end of extension wire (PIEZO23WH) to the orange ignitor wire and attach the 1/4" wire end (PIEZO48WH) wire to ground tab under the burner pan. See Fig. 20.

Step 9: Test the ignitor by pushing and holding the red button to ensure the 2-probe ignitor is sparking inside the ignition box in the burner pan. The spark should be located directly over top of the burner port hole for proper ignition of the gas as previously discussed. Spacing between the probes should be approximately 1/8" for proper spark. See Fig. 18.

Step 10: Install the ignition hood screen mesh and ensure no media lays on the screen mesh area (See Fig. 21). Install the lava rock/media material according to fire pit install manual and turn the main gas supply back ON. Installation is now complete.

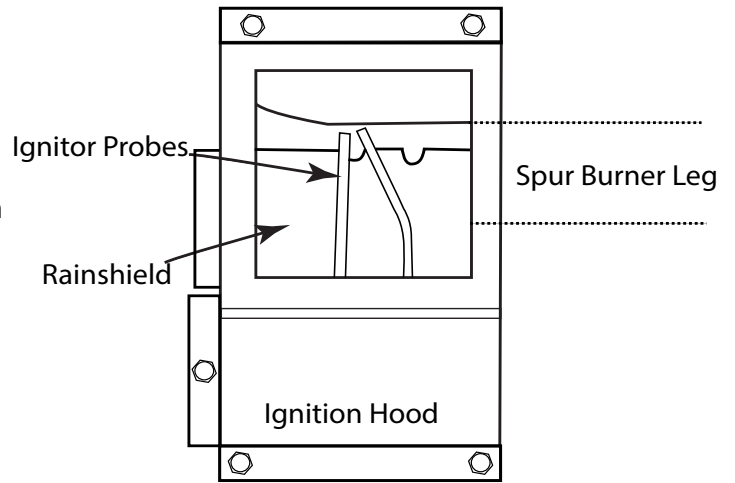

Fig. 18 Installing ignition hood.

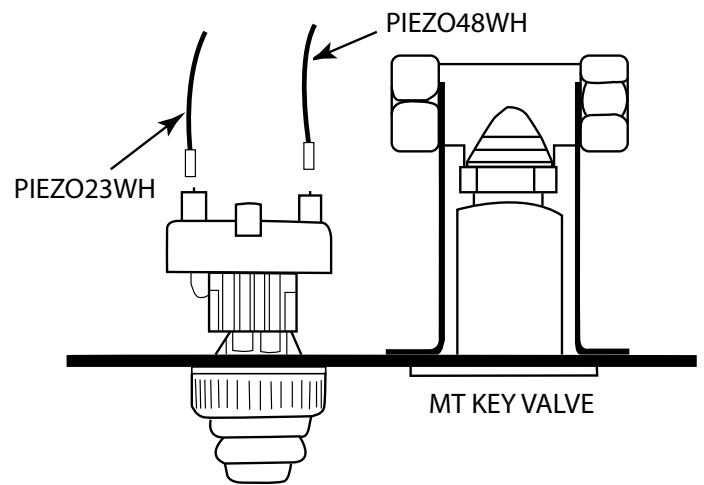

Fig. 19 Wiring into the Piezo module.

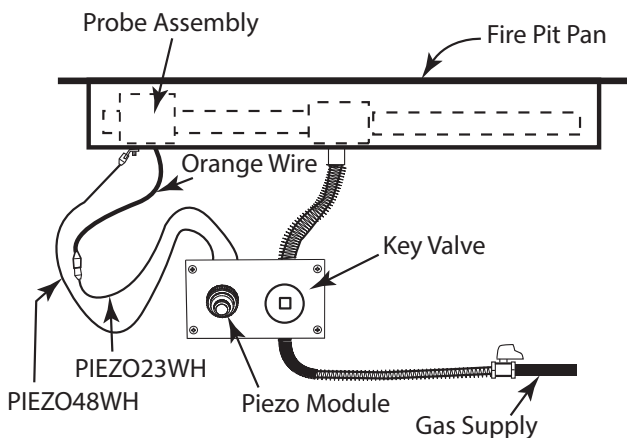

Fig. 20 Wiring diagram PAVER-CP-MT-MSI.

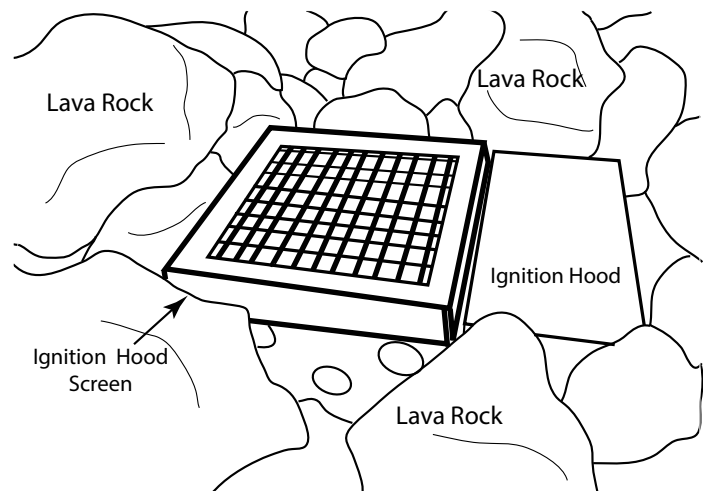

Fig. 21 Installing screen mesh cover on ignitor hood.

MT-MSI LIGHTING INSTRUCTIONS

READ ALL LIGHTING INSTRUCTIONS BEFORE ATTEMPTING TO LIGHT FIRE PIT

CAUTION: ENSURE YOU HAVE LEAK TESTED THE FIRE PIT BEFORE OPERATING.

WARNING: Do not stand over fire pit during ignition or operation due to high surface temperatures.

LIGHTING INSTRUCTIONS

TURNING ON FIRE PIT

1. Depress and hold the red Piezo ignitor button and ensure sparking is occurring at the probes inside ignition hood.
2. Insert key into gas valve and turn counter clockwise to the ON position.
3. After the fire pit lights release the Piezo button. If fire pit does not light within 30 seconds, turn key clockwise to turn OFF and wait 5 minutes before trying again. Turn gas supply OFF to check probe spacing and Piezo battery if fire pit does not light.
4. Repeat steps 1-4.

TURNING OFF FIRE PIT

1. Insert key and turn clockwise to OFF. Fire pit will turn OFF.
2. After cooling off install cover (if applicable).



Red Piezo Button

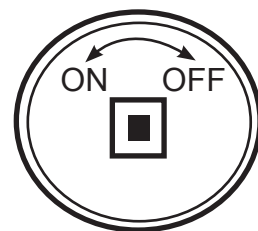

Key Valve

Fig. 22 Piezo button and key valve.

FOR TECHNICAL SERVICE, CALL:

Firegear Outdoors, an Earthcore Industries Brand
1600 Riverfork Drive
Huntington, IN 46750
260-388-5653
techsupport@firegearoutdoors.com

Manual changes often occur, ensure to check the Firegear website for any recent updates and warranty information.

PAVER-CP-MT / PAVER-CP-MT-MSI REPLACEMENT PARTS

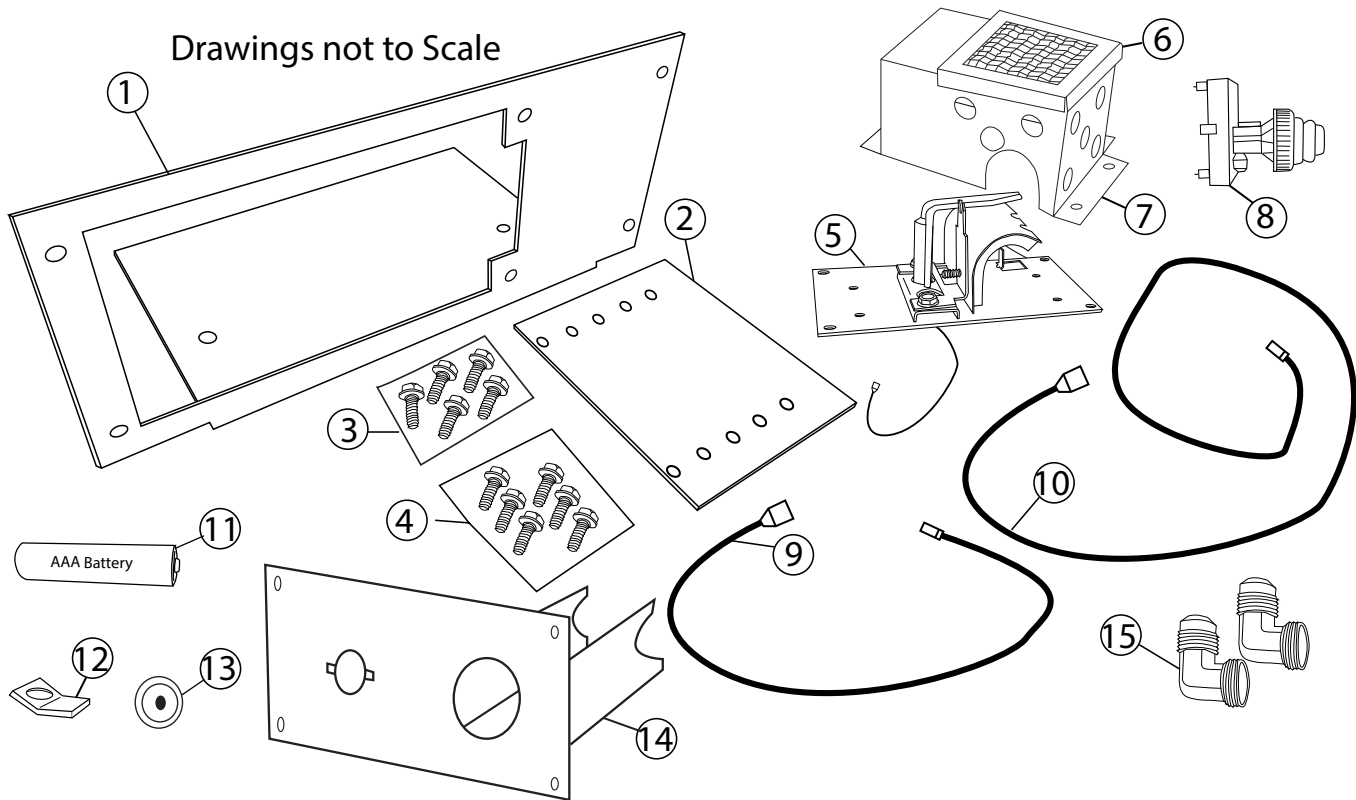

Item #	Qty.	Description	Part Number	MT	MT-MSI
1	1	Paver Kit Bracket	PAVERKITBRACKET-SS	x	x
2	1	Paver Kit Bracket Extension	PAVERKITBRACKETEXT-SS	x	x
3	5	10-24 x 1/2" SS Thread Cutting Screw	ST3-113-1028	x	x
4	6	3/4" Stainless Thread Cutting Screw	SCREW1024HXSS75	x	x
5	1	MSI Ignitor Assembly (24" orange wire)	MSI-IGNT-ASSEMBLY		x
6	1	Ignition Hood Screen	ST3-100-1027		x
7	1	Ignition Hood	SPURHOOD		x
8	1	Ignition Module	3042-RB		x
9	1	23" Piezo Ignition Wire	PIEZO23WH		x
10	1	48" Piezo Ignition Wire	PIEZO48WH		x
11	1	AAA Battery	BATTAAA		x
12	1	1/4" Male Spade Terminal	GROUNDTAB	x	x
13	1	Black Nylon Plug	BPFE-15-MM	x	x
14	1	Match Throw (MT) Face Plate	MT-FACEPLATE	x	x
15	2	1/2" Flare x 1/2" MIP Brass Elbow	49-88	x	x
16	2	1/4" x 1 1/4" Concrete Screws (not shown)	SCREW.25MASONRY	x	x
17	1	3" X 12" Steel lintel (not shown)	PAVER-LINTEL	x	x

* Some part quantities will vary depending upon kit used.

Note: Item #12 is supplied with the fire pit; it is only listed as a replacement part.