

KEY FEATURES

Fits Models:

- F36S-B
- F36S-B-NG
- F36S-Pro-B
- F36S-Pro-B-NG

Uses:

- Non-Combustible Islands
- Overlap Finish Installs
- Retro-Fit Into Large Openings
 - Width - 38.5" to 39.75"
 - Depth - 25.25" to 25.75"
 - Height - 12" to 13.5"
- Natural Gas or Propane Installs

Benefits:

- All 304 Stainless Steel
- Brushed #4 Finish
- Limited Lifetime Warranty

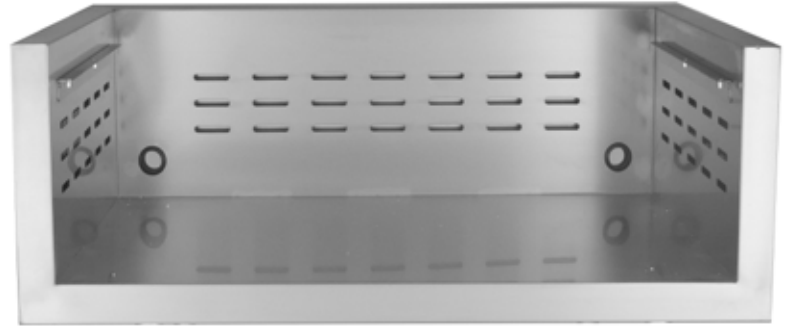

F36S-B | F36S-B-NG



F36S-Pro-B | F36S-Pro-B-NG

TECHNICAL SPECS

- Dimensions:** 40" W | 26" D | 14" H
- Package Dimensions:** 44" W | 30" D | 18" H
- Package Weight:** 58 LBS
- Grill Type:** Built-In
- Clearance To Combustibles:** Sides: 0"
Rear: 0"
Bottom: 0"
- Cutout Dimensions:** Width: 38.5" (A)
Depth : 25.5" (B)
Height: 12" (C)
- Island Dimensions (Recommended):** Depth: 30" (D)
Height: 36" (E)
- Notch Dimensions (Optional)*** Width: 40.25" (F)
Depth: Determined by
finish face material.

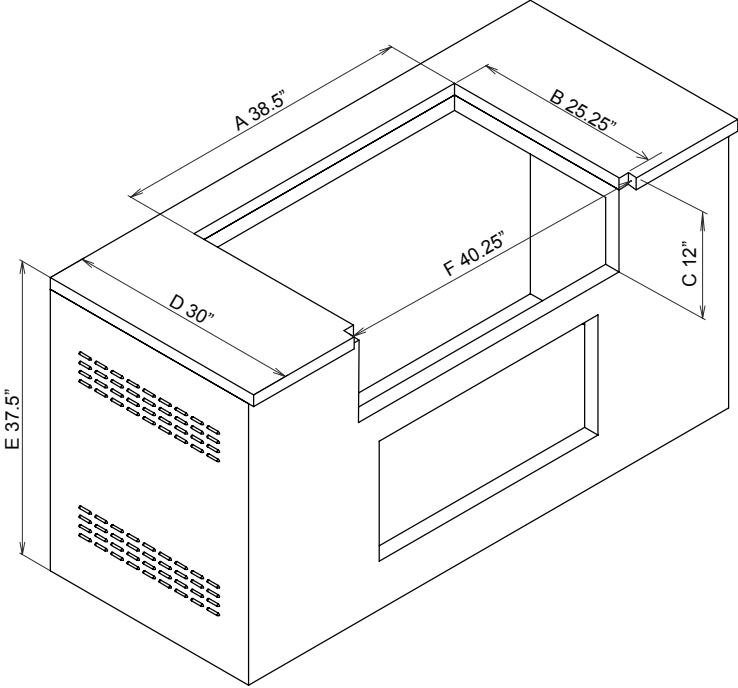

*Recommended to notch the countertop so that front edge overlaps finished island face material.

